

800X₂

specifications

Operating Weight: 178,600 lbs (81,000 kg)
 SAE Net Horsepower:
 with fan pump 495 HP (369 kW)
 without fan pump 532 HP (397 kW)
 Bucket Range: 2.47 - 5.91 yd³ (1.89 - 4.52 m³)

Engine

Isuzu AH-6WG1XYSS-02 Tier 3 turbocharged diesel engine with electronic fuel control, 6-cylinder, water-cooled, EGR with cooler, air-to-air intercooler, fuel cooler, auto idle-start, neutral safety start, glow plugs, auto warm-up, EPF engine protection, dual stage fuel filtration, remote oil filter, green plug oil drain.

SAE net horsepower

with fan pump 495 HP (369 kW) @ 1,800 rpm
 without fan pump 532 HP (397 kW) @ 1,800 rpm
 Displacement 15.7 L
 Maximum torque 1,660 lbf-ft (2,250 N-m) @ 1,500 rpm
 Starter 24V-7.0kW
 Alternator 50 amp
 Battery 140 amp hours

Cab and Controls

Pressurized cab with climate control a/c and heat with defroster, LCD monitor, illuminated soft-touch switches, low-effort controls pre-wired for auxiliary hydraulics, control pattern changer, sliding LEXAN® MARGARD® windows, safety glass front window with automatic locking system and vandal cover, intermittent windshield wiper with washer, emergency rear window exit, polycarbonate roof hatch with sunshade, shockless cab suspension with four fluid mountings, KAB® reclining air-suspension seat, sliding 4-position tilting control consoles, AM/FM radio, digital clock, dome light, seat belt, coat hook, cup holder, storage compartments, floor mat, footrests, ashtray, 24-volt cigarette lighter, 12-volt outlet, travel alarm, handrail, mirrors.

Four selectable working modes, anti-theft password protection system, on-board self-diagnostic system with memory, auto-idling system, one-touch decelerator, auto power boost, gate lock safety shutoff.

A/C output 18,100 BTU/hr
 Heater output 20,150 BTU/hr
 Sound level (inside cab) 69.3 dB(A)
 Sound level (exterior) 105.8 dB(A)

Hydraulic System

Open-center system, two variable displacement axial piston pumps and one gear pump for pilot controls, main control valve with one 4-spool valve and one 5-spool valve with auxiliary spool - stackable, oil cooler, auto power boost, boom and arm holding valves, o-ring face seals, 6 micron return filter, firewall.

Hydraulic Pumps

Maximum flow 2 x 132 gpm (2 x 500 l/min)
 Pilot pump maximum flow 7.1 gpm (27 l/min)

Relief Valve Settings

Boom / Arm / Bucket 4,550 psi (314 bar)
 in Power-Boost Mode 4,980 psi (343 bar)
 Swing circuit 3,840 psi (265 bar)
 Travel circuit 4,980 psi (343 bar)

Hydraulic Cylinders

number of cylinders – bore x rod x stroke.
 Boom 2 – 7.9" x 5.5" x 74.5"
 (200 mm x 140 mm x 1 893 mm)
 Arm 1 – 8.5" x 5.9" x 90.2"
 (215 mm x 150 mm x 2 290 mm)
 Bucket 1 – 7.5" x 5.1" x 61.2"
 (190 mm x 130 mm x 1 555 mm)
 Bucket (Mass excavator) 1 – 8.5" x 5.9" x 59.8"
 (215 mm x 150 mm x 1 520 mm)

Hydraulic Oil Filtration

Return filter 6 micron
 Pilot filter 8 micron
 Suction screen 105 micron



Swing

Planetary reduction powered by axial piston motor. Internal ring gear with grease cavity for swing pinion. Swing bearing is single-row shear type ball bearing. Mechanical disc swing brake. Auto power swing.

Swing speed 0 – 6.4 rpm
 Tail swing 14' 1" (4.30 m)
 Swing torque 196,600 lbf-ft. (266.5 kN•m)

Undercarriage

X Pattern carbody with sealed and strutted track chain, sealed rollers and idlers, two-speed independent hydrostatic travel with compact planetary final drive, disc type brakes, adjustable track tension, swivel guard.

Carrier rollers 3 per side
 Track rollers 9 per side
 Track link pitch 10.24" (260 mm)
 Shoes 51 per side
 Shoe width 36" (900 mm)
 Ground pressure 13.92 psi (0.96 bar)

Lubricant and Coolant Capacity

Fuel tank 238.0 gal. (900 liters)
 Hydraulic tank 82.0 gal. (310 liters)
 Hydraulic system 190.0 gal. (720 liters)
 Final drive (per side) 3.65 gal. (13.8 liters)
 Swing drive 3.57 gal. (13.5 liters)
 Engine oil 13.7 gal. (52 liters)
 Cooling system 35 gal. (133 liters)

Travel System

Two-speed independent hydrostatic travel with compact axial piston motors. Hydraulic motor powered output shaft coupled to a planetary reduction unit and track sprocket. All hydraulic components mounted within the width of side frame. Automatic downshift. Spring applied, hydraulically released disc parking brake built into each motor. Each travel motor equipped with counterbalance valve to prevent overspeeding down an incline.

Max. travel speed 1.8 - 2.6 mph (2.9 - 4.2 km/h)
 Drawbar pull 127,000 lbf (565 kN)
 Gradeability 70% (35°)

Attachment

Excavator Boom (Standard) 27' 7" (8.40 m)
 Excavator Boom (Mass) 23' 9" (7.25 m)

Available Arms (Standard)

• 12' 0" (3.66 m) 61,600 lbf (274 kN)
 with Auto Power-Boost applied 67,440 lbf (300 kN)
 • 14' 7" (4.44 m) 52,160 lbf (232 kN)
 with Auto Power-Boost applied 56,880 lbf (253 kN)
 • 18' 5" (5.62 m) 43,840 lbf (195 kN)
 with Auto Power-Boost applied 48,110 lbf (214 kN)

Digging Force*

Bucket Digging Force 74,190 lbf (330 kN)
 with Auto Power-Boost applied 81,160 lbf (361 kN)

Available Arms (Mass)

• 9' 9" (2.98 m) 71,260 lbf (317 kN)
 with Auto Power-Boost applied 78,010 lbf (347 kN)
 Bucket Digging Force 96,670 lbf (430 kN)
 with Auto Power-Boost applied 105,660 lbf (470 kN)

Digging Force*

*Digging force ratings are based on ISO 6015, "Earthmoving Machinery – Hydraulic Excavators – Tool Forces."

Operating Weight

Standard Excavator - Working weight with 29.5" (700 mm) shoes, 27' 7" (8.40 m) boom, 12' 0" (3.66 m) arm 6,614 lb. (3 000 kg) bucket, 27,600 lb. (12,500 kg) counterweight 178,600 lbs (81,000 kg)
Mass Excavator - Working weight with 29.5" (700 mm) shoes, 23' 9" (7.25 m) boom, 9' 9" (2.98 m) arm 7,628 lb. (3 460 kg) bucket, 27,600 lb. (12,500 kg) counterweight 178,800 lbs (81,100 kg)

800 X2 Specifications

Working Ranges

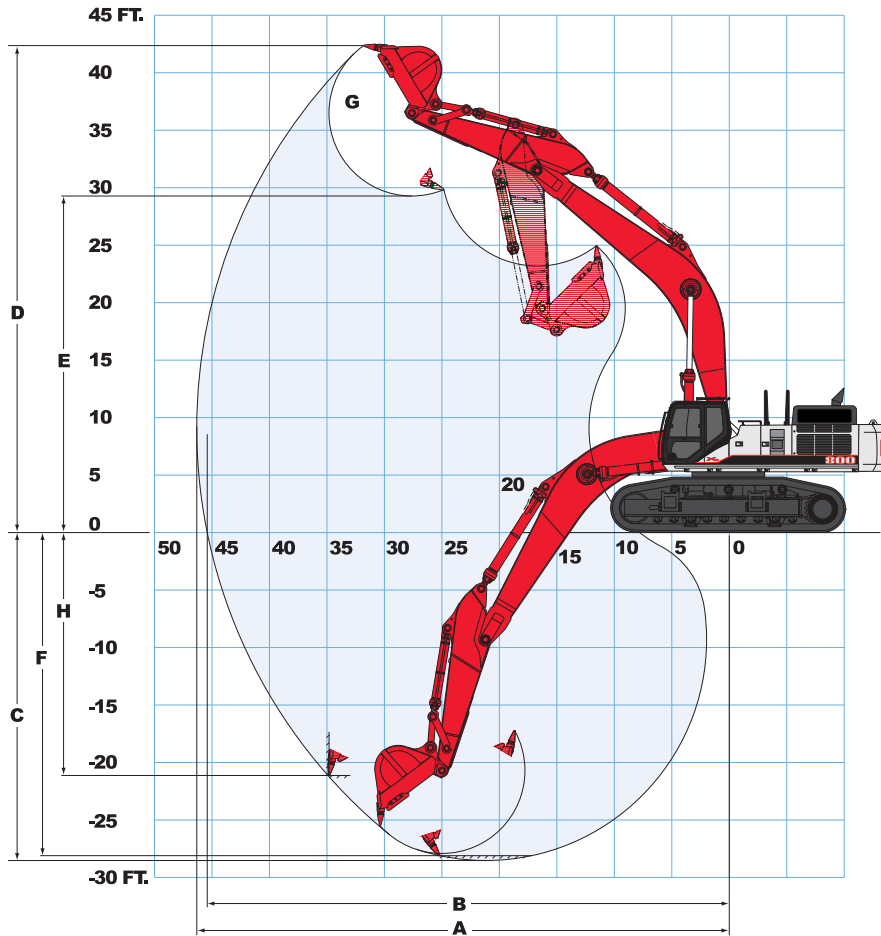

800 X2

Machine equipped with 27' 7" (8.40 m) boom	12' 0" Arm (3.66 m)	14' 7" Arm (4.44 m)	18' 5" Arm (5.62 m)
A. Maximum reach	46' 4" (14.12 m)	49' 0" (14.94 m)	52' 10" (16.11 m)
B. Maximum reach @ ground level	45' 5" (13.84 m)	48' 2" (14.68 m)	52' 0" (15.86 m)
C. Maximum dig depth	28' 6" (8.69 m)	31' 1" (9.47 m)	34' 8" (10.56 m)
D. Maximum dig height	42' 4" (12.91 m)	44' 7" (13.60 m)	46' 11" (14.30 m)
E. Maximum dump height	29' 3" (8.92 m)	31' 2" (9.51 m)	33' 4" (10.17 m)
F. Digging depth - 8' (2.44 m) level bottom	28' 1" (8.57 m)	30' 9" (9.36 m)	34' 8" (10.56 m)
G. Bucket rotation	167°	167°	167°
H. Maximum vertical wall depth	21' 2" (6.44 m)	25' 5" (7.75 m)	29' 11" (9.11 m)

800 X2 Mass Excavator

Machine equipped with 23' 9" (7.25 m) boom	9' 9" Arm (2.98 m)
A. Maximum reach	40' 5" (12.31 m)
B. Maximum reach @ ground level	39' 4" (11.99 m)
C. Maximum dig depth	23' 1" (7.03 m)
D. Maximum dig height	38' 7" (11.76 m)
E. Maximum dump height	25' 11" (7.89 m)
F. Digging depth - 8' (2.44 m) level bottom	22' 7" (6.88 m)
G. Bucket rotation	162°
H. Maximum vertical wall depth	13' 11" (4.25 m)

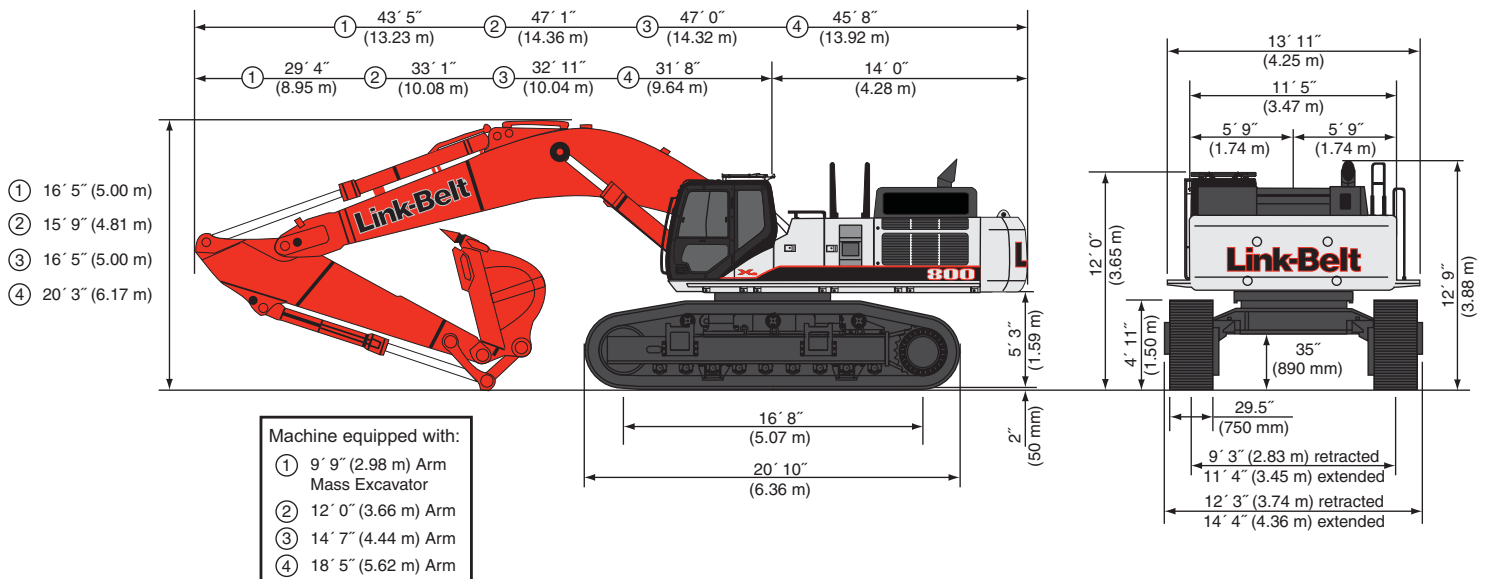

Preliminary Transportation Specifications

Catwalk

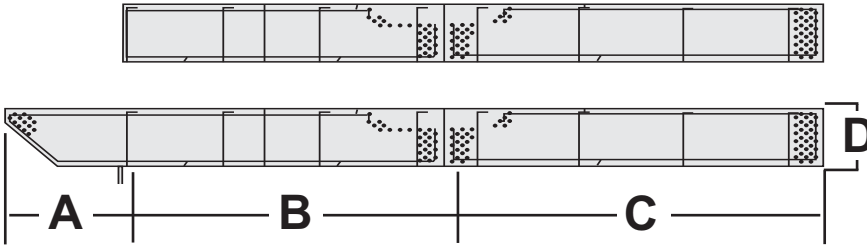

Weight:

Right side - 3 sections
Total weight: 139 lbs. (63 kg)

Left side - 4 sections
Total weight: 179 lbs. (81 kg)

Dimension A: 1' 4" (400 mm)

Dimension B: 7' 9" (2.35 m)

Dimension C: 8' 5" (2.57 m)

Dimension D: 1' 4" (400 mm)

Boom with Arm Cylinder and Piping

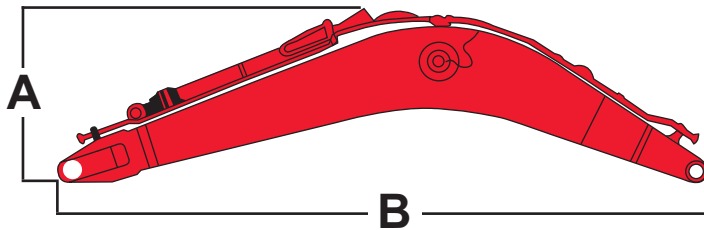

BOOM	A	B	Width	Weight
Standard	7' 7" (2.31 m)	28' 9" (8.75 m)	4' 10" (1.47 m)	18,298 lbs. (8 300 kg)
Mass	8' 5" (2.56 m)	25' 9" (7.85 m)	4' 10" (1.47 m)	17,196 lbs. (7 800 kg)

Arm with Bucket Cylinder and Linkage

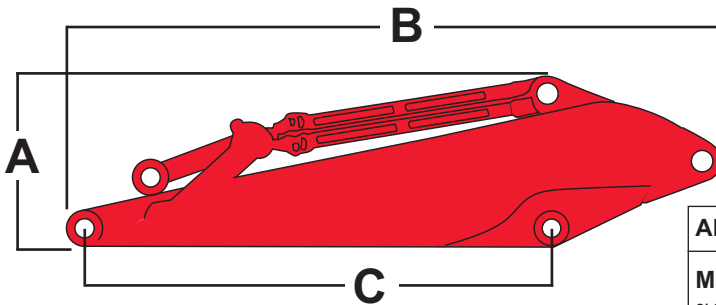

ARM	A	B	C	Width	Weight
Mass 9' 9" (2.98 m) arm	4' 11" (1.50 m)	14' 5" (4.38 m)	9' 9" (2.98 m)	2' 5" (.735 m)	9,370 lbs. (4 250 kg)
Standard 12' 0" (3.66 m) arm	4' 7" (1.39 m)	17' 1" (5.20 m)	12' 0" (3.66 m)	2' 5" (.735 m)	9,039 lbs. (4 100 kg)
Standard 14' 7" (4.44 m) arm	4' 3" (1.29 m)	19' 5" (5.91 m)	14' 7" (4.44 m)	2' 5" (.735 m)	9,312 lbs. (4 224 kg)
Standard 18' 5" (5.62 m) arm	4' 2" (1.28 m)	23' 2" (7.06 m)	18' 5" (5.62 m)	2' 5" (.735 m)	10,478 lbs. (4 752 kg)

Boom Cylinder

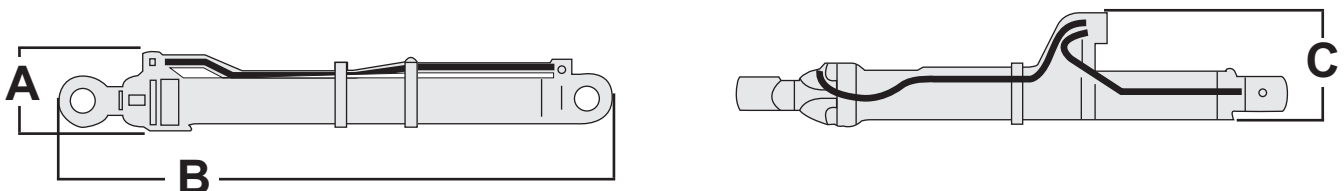

Boom Cylinder: Weight: 1,775 lbs. (805 kg) Dimension A: 1' 3" (.40 m)
Dimension B: 9' 7" (2.93 m)
Dimension C: 2' 2" (.67 m)

800 X2 Specifications

Preliminary Transportation Specifications

Upper Structure w/TTB Counterweight and Lower Cross Frame

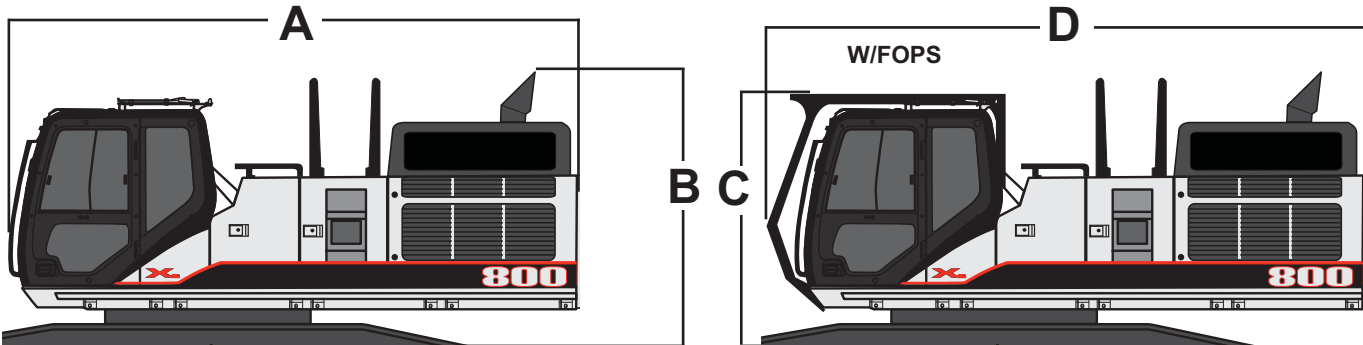

Weight: 55,778 lbs. (25 300 kg)
Weight: W/FOPS 56,284 lbs. (25 530 kg)

Dimension A: 17' 8" (5.38 m)
 Dimension B: 9' 9" (2.96 m)
 Dimension C: 9' 2" (2.80 m)
 Dimension D: 19' 3" (5.88 m)

FOPS Head Guard:
 (Optional)
 Weight: 506 lbs. (230 kg)

Counter Weight

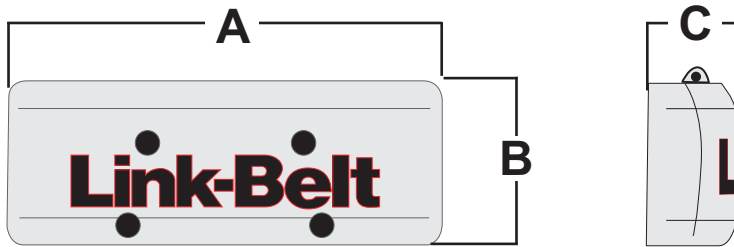

Weight: 27,600 lbs. (12 500 kg)
 Dimension A: 11' 5" (3.47 m)
 Dimension B: 4' 7" (1.39 m)
 Dimension C: 2' 9" (.83 m)

Hand Rails

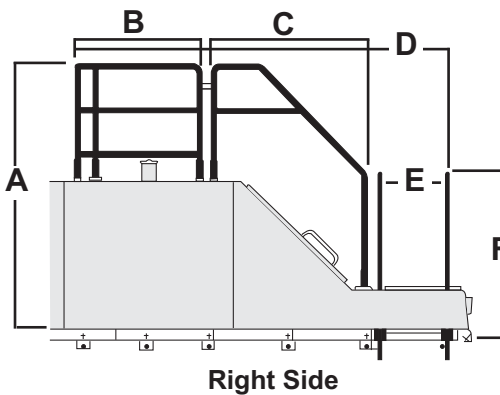

Total Weight: 159 lbs. (72 kg)

Dimension A: 6' 5" (1.95 m)
 Dimension B: 1' 9" (.54 m)
 Dimension C: 1' 6" (.47 m)
 Dimension D: 5' 11" (1.80 m)
 Dimension E: 1' 8" (.50 m)
 Dimension F: 5' 0" (1.53 m)
 Dimension G: 1' 11" (.60 m)
 Dimension H: 2' 9" (.84 m)

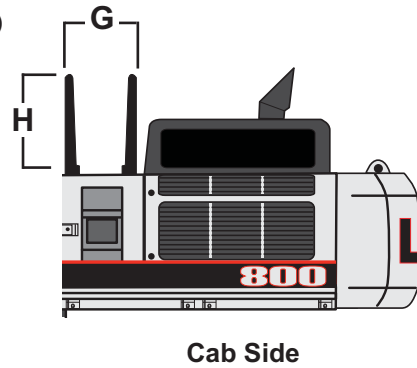

Undercarriage

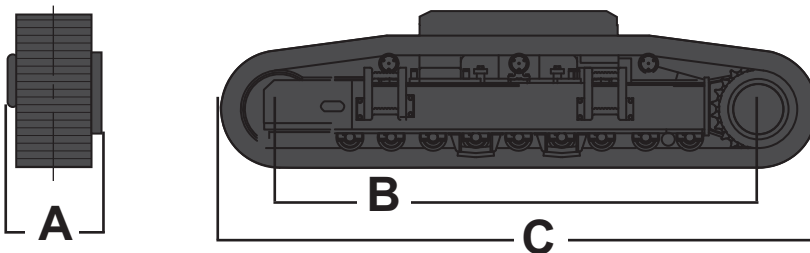

Side Frame with Steps:

Shoe Width	Weight: (per side)
26" (650 mm)	27,558 lbs. (12 500 kg)
30" (750 mm)	28,440 lbs. (12 900 kg)
36" (900 mm)	29,542 lbs. (13 400 kg)

Dimension A:

W/ 26" (650 mm) shoes - 39.8" (1012 mm)
 W/ 30" (750 mm) shoes - 39.8" (1012 mm)
 W/ 36" (900 mm) shoes - 39.8" (1012 mm)

Dimension B: 16' 8" (5070 mm)

Dimension C: 20' 10" (6355 mm)

800 X2 Specifications

Lifting Capacities 800 X2

12' 0" (3.66 m) Arm with 27' 7" (8.40 m) Boom and 6,600 lb. (2 994 kg) Bucket with Power-Boost Applied

	Radius of Load														Cap. at Max. Reach			
	10' 0" (3.05 m)		15' 0" (4.57 m)		20' 0" (6.10 m)		25' 0" (7.62 m)		30' 0" (9.14 m)		35' 0" (10.66 m)		40' 0" (12.19 m)				End	Side
	End	Side	End	Side	End	Side	End	Side	End	Side	End	Side	End	Side	End	Side		
+35' 0" lbs 10.66 m (kg)																	13,650*	13,650*
+30' 0" lbs 9.14 m (kg)																	6 192*	6 192*
+25' 0" lbs 7.62 m (kg)																	13,100*	13,100*
+20' 0" lbs 6.10 m (kg)																	5 942*	5 942*
+15' 0" lbs 4.57 m (kg)																	12,900*	12,900*
+10' 0" lbs 3.05 m (kg)																	5 851*	5 851*
Ground Line (kg)																	12,950*	12,950*
-5' 0" lbs -1.52 m (kg)																	5 874*	5 874*
-10' 0" lbs -3.05 m (kg)																	17,700*	17,700*
-15' 0" lbs -4.57 m (kg)																	8 029*	8 029*
-20' 0" lbs -6.10 m (kg)																	25,600*	25,600*
-25' 0" lbs -7.62 m (kg)																	11 612*	11 612*
																	8 437	8 437
																	13,300*	13,300*
																	6 033*	6 033*
																	13,900*	13,900*
																	6 305*	6 305*
																	14,800*	14,100
																	6 713*	6 396
																	16,100*	14,700
																	7 303*	6 668
																	18,000*	16,050
																	8 165*	7 280
																	20,850*	18,500
																	9 458*	8 392

14' 7" (4.44 m) Arm with 27' 7" (8.40 m) Boom and 6,378 lb. (2 893 kg) Bucket with Power-Boost Applied

	Radius of Load														Cap. at Max. Reach					
	10' 0" (3.05 m)		15' 0" (4.57 m)		20' 0" (6.10 m)		25' 0" (7.62 m)		30' 0" (9.14 m)		35' 0" (10.66 m)		40' 0" (12.19 m)				45' 0" (13.72 m)		End	Side
	End	Side	End	Side	End	Side	End	Side	End	Side	End	Side	End	Side	End	Side	End	Side		
+40' 0" lbs 12.19 m (kg)																			9,100*	9,100*
+35' 0" lbs 10.66 m (kg)																			4 128*	4 128*
+30' 0" lbs 9.14 m (kg)																			8,250*	8,250*
+25' 0" lbs 7.62 m (kg)																			3 742*	3 742*
+20' 0" lbs 6.10 m (kg)																			7,800*	7,800*
+15' 0" lbs 4.57 m (kg)																			3 538*	3 538*
+10' 0" lbs 3.05 m (kg)																			7,600*	7,600*
+5' 0" lbs 1.52 m (kg)																			3 447*	3 447*
Ground Line (kg)																			7,550*	7,550*
-5' 0" lbs -1.52 m (kg)																			3 425*	3 425*
-10' 0" lbs -3.05 m (kg)																			27,750*	27,750*
-15' 0" lbs -4.57 m (kg)																			12 587*	12 587*
-20' 0" lbs -6.10 m (kg)																			11 544*	11 363
-25' 0" lbs -7.62 m (kg)																			25,450*	25,050
																			10 886*	10 886*
																			6 736*	6 736*
																			14,850*	14,850*
																			10 886*	10 886*
																			21,500*	19,600
																			9 752*	8 891
																			24,200*	19,000
																			10 977*	8 618
																			11,450*	11,450*
																			11 680*	8 301
																			5 194*	5 194*
																			8,050*	8,050*
																			3 651*	3 651*
																			8,650*	8,650*
																			13,000*	13,000*
																			3 924*	3 924*
																			9,450*	9,450*
																			4 287*	4 287*
																			10,600*	10,600*
																			4 808*	4 808*
																			12,350*	12,350*
																			5 602*	5 602*
																			15,000*	15,000*
																			6 804*	6 804*

800 X2 Specifications

Bucket Sizes 800 X2

Bucket Type	SAE Heaped Capacity		Width Outside Lip		Bucket Weight		Number of Teeth	Standard Excavator Arm Length			Mass Excavator
	(yd ³)	(m ³)	(in)	(mm)	(lbs)	(kg)		12'-0" 3.66 m	14'-6" 4.42 m	18'-5" 5.61 m	9'-9" 2.98 m
HDP	2.53	1.93	42	1067	6403	2904	4	H	H	H	H
	3.00	2.29	48	1219	6803	3086	4	H	H	M	H
	3.48	2.66	54	1372	7203	3267	4	H	M	L	H
	3.96	3.03	60	1524	7780	3529	5	M	M	L	H
	4.45	3.40	66	1676	8180	3710	5	M	L	N/A	H
	4.94	3.78	72	1829	8580	3892	5	L	L	N/A	H
	5.42	4.14	78	1981	9157	4154	6	L	N/A	N/A	H
XDP	5.91	4.52	84	2134	9557	4335	6	L	N/A	N/A	M
	2.47	1.89	45	1143	6470	2935	4	H	H	H	H
	3.26	2.49	56	1422	7211	3271	4	H	H	M	H
	3.99	3.05	66	1676	8061	3656	5	M	M	L	H
	4.43	3.39	72	1829	8466	3840	5	M	L	N/A	H
	5.30	4.05	84	2134	9451	4287	6	L	N/A	N/A	H

HDP - Heavy duty plate
XDP - Extreme duty plate

Approval Code For Arm/Bucket Combinations

H..... Heavy material
(up to 3,370 lbs./yd³)

M..... Medium material
(up to 2,700 lbs./yd³)

L..... Light material
(up to 2,020 lbs./yd³)

N/A..... Not applicable

Notes: Excavator lifting capacities

- Lifting capacities shown should not be exceeded. Weight of all lifting accessories must be deducted from the above lifting capacities.
- Lifting capacities are based on machine standing on firm, uniform supporting surface. User must make allowances for job conditions such as soft or uneven ground.
- Lifting capacities shown do not exceed 75% of minimum tipping loads or 87% of hydraulic capacities. **Capacities marked with an asterisk (*) are limited by hydraulic capacities.**
- Least stable position is over the side.
- Operator should be fully acquainted with the Operator's Manual & Operating Safety Booklet, furnished by LBX before operating the machine.
- Capacities apply only to the machine as originally manufactured and normally equipped by LBX Company LLC.
- Lift capacity ratings are based on SAE J1097, "Earthmoving Machinery – Hydraulic Excavators – Lift Capacity".

800 X2 Specifications

Standard Equipment

- KAB 855 sliding/reclining air-suspension seat with adjustable 4-inch armrests, lumbar support and retractable seat belt
- Safety glass front window with auto lock, windshield wiper and washer with intermittent speeds, Lexan® side and rear tinted windows
- 4-position tilting consoles with memory position and hydraulic lock-out
- Auto climate control a/c and heat
- AM/FM stereo with mute button, horn, interior light, digital clock, hour meter, floor mat, cup holder, sun shade, storage, LH and RH rear view mirrors
- Travel alarm with cancel switch
- Vandal guarding with bolt-on FOG capability
- EPA Tier III Isuzu diesel engine
- Common rail fuel injection
- Turbocharger with intercooler
- Neutral safety start
- Idle start
- Glow plug pre-heat
- Auto engine warm-up
- Reversible cooling fan
- Auto idling system
- One-touch idle
- Dual remote fuel filters with water separation
- Double element air filter with in-cab restriction indicator
- Reversible fan
- External fuel gauge
- Remote, full-flow engine oil filter
- Green plug engine oil drain
- EPF Engine Protection
- Emergency engine stop
- Open-center hydraulic system
- Four selectable work modes including attachment mode
- Auto power boost
- Auto swing priority
- Pre-set auxiliary pump settings - 10
- Auxiliary valve
- Stackable main control valve
- Auxiliary pipe brackets
- Control levers pre-wired for auxiliary
- Control pattern changer
- Long undercarriage
- Sealed and lubricated track chain
- Two-speed with auto shift and straight travel
- Planetary drive
- Spring-applied, hydraulic release brake
- Hydraulic track adjust
- Swivel guard belly pan
- Track guides
- Vandal locks with common key
- 27,600 lb (12,500 kg) counterweight with lifting eyes
- Hand rail
- Tool box
- Catwalks
- EMS (Extended Maintenance System) 1,000 hour service interval throughout entire attachment except bucket
- HD bucket linkage
- Attachment cushion valve
- Arm and boom speed assistance
- Arm and boom regeneration
- Arm and boom holding valves
- Cylinder cushion
- Centralized lube bank
- Bucket anti-clatter device
- Illuminated LCD service monitor
- On-board diagnostic system
- Anti-theft device
- 12-volt accessory outlet
- 70-watt work lights on boom and upper

Options

- Booms
 - 27-ft 7-in (8.40 m) Standard
 - 23-ft 9-in (7.25 m) Mass
- Arms
 - 9-ft 9-in (2.98 m)
 - 12-ft 0-in (3.60 m)
 - 14-ft 7-in (4.44 m)
 - 18-ft 5-in (5.62 m)
- Tracks
 - 36-in (900 mm) 3-bar grouser
 - 26-in (650 mm) 2-bar grouser
 - 30-in (750 mm) 2-bar grouser
- Hydraulics
 - Single-acting with switch activation
 - Multi-function with switch activation
 - Thumb hydraulics with switch activation
- Coupler
 - ESCO quick-coupler
- Hydraulic counterweight removal
- Free swing
- Fog guard
- Front guard - mesh or bars
- Full-length track guards



LBX Company is the proud maker of quality Link-Belt excavators and is located in Lexington, KY.



www.lbxco.com

Litho in USA 3/11 #LBX2171

© LBX and © Link-Belt are registered trademarks. Copyright 2011. All rights reserved. We are constantly improving our products and therefore reserve the right to change designs and specifications.