

Link-Belt
EARTHMOVING • FORESTRY
MATERIAL HANDLING EQUIPMENT

290Lx

Operating Weight: 64,400 lbs (29 200 kg)

SAE Net Horsepower: 177 HP (132 kW)

Bucket Range: .79 - 2.43 cu. yd. (.60 - 1.86 cu. m.)



Designed for Durability and Performance...

Smarter. Faster. Better.

Inte-LX® or *Intelligent LX* is the most advanced technology to date. *Inte-LX*® maximizes the balance between speed, power, and fuel efficiency. *Page 4*

First Electronic Engine Control in an Excavator

This results in increased responsiveness to the job requirements; faster cycle times, increased fuel efficiency, cleaner and quieter. *Page 6*

Reduced Maintenance and Extended Component Life

The Nephron® Filtration system means less wear and tear on the hydraulic components, reducing hydraulic system breakdowns and maintenance costs. *Page 8*

Faster Cycle Times

A smarter more efficient hydraulic system uses dual pump flow, auto power swing and regenerative circuits for increased productivity. *Page 5*

Anti-Theft System

To protect your investment, a password protected anti-theft system comes as standard equipment and can be activated at the users choice. *Page 4*

Superior Serviceability

On-board diagnostics with memory and fewer hydraulic oil changes result in superior serviceability. *Page 8*

Exceptional Travel Performance

High torque travel motors automatically shift to provide increased tractive effort when operating in difficult ground conditions. *Page 5*

Maximized Operator Comfort

The industry's largest cab providing low noise, climate controlled heat and air conditioning, standard. *Page 3*

Auto Power-Up

Auto power-up automatically increases system pressure by 9% to power through tough ground or when lifting a heavy load. *Page 4*

Cleaner Side-Wall Cuts

With Auto Power-Swing, *Inte-LX*® automatically prioritizes swing torque when simultaneously working the swing and attachment. *Page 5*

Low Ground Pressure and Exceptional Stability

LC undercarriage for low ground pressure and stability incorporates heavy-duty excavator style components. *Page 7*

Long Life Pin and Bushing Design

Chrome pins and grease impregnated bushings at the boom foot and the boom to arm connection hold up to the torsional stresses at these key attachment points and reduces the greasing interval. *Page 7*

Heavy Duty Boom and Arm

Built to handle powerful breakout forces, strong lifting capacities and the stresses of allied attachments. *Page 7*



Operator's Control Station

Large, Low Noise Cab Design

A wide cab design provides expanded leg and elbow room. **Six silicon filled isolation mounts** float the entire cab above the noise and vibration of an already quiet machine greatly reducing operator fatigue. Large entry door and access width makes entering and exiting the cab a breeze.

Control Panel

Many machine function switches are concentrated in a panel in clear view and easy reach of the operator.

Tilting Console and Sliding Seat

The seat slides independently of the control consoles to assure optimal joystick positions at all times.

The joysticks can be tilted to any of three settings, allowing the operator to work in the most comfortable position. The entire platform can then be moved forward or backward for best foot pedal positioning.



Panoramic Visibility

This cab provides more window space than ever. Even the sunroof is large. The Operator's "office with a view" has rear and side windows made of LEXAN® MARGUARD™. Standard vandal covers protect the safety glass front windows and stow on top when you're working.

Informative LCD Monitor

Large size LCD Monitor displays graphically a wide range of operating information such as; engine temperature, hydraulic oil temperature, fuel level, travel speed, work mode and engine idle. Additional messages include system/machine warnings and service due messages in your choice of English and 13 other languages. Backlit illumination ensures displays are always readable – day and night.



All Weather Visibility

With built-in washer and intermittent speed control, the wiper keeps your windshield clear, whatever the condition outside. The "rise-up" design takes the wiper arm and blade out of the line of sight when its not in use, plus lifts the blade from the cab surface so that it doesn't freeze to the cab in icy weather.

Fresh Air Induction-Type Climate Control

LX provides exceptional heating/cooling capabilities with a climate control system that automatically regulates the temperature for the operator's comfort. Now with 6 vents, LX Series excavators provide exceptional air circulation for optimum operator comfort. Front-side air outlet and defroster ensure a comfortable operating environment while the open/close type rear window further improves the ventilation.



Best Seat at the Site

The KAB 515 seat adjusts to your size and comfort. The semi-bucket seat provides firm support and comfort with armrests, adjustable seat suspension, adjustable lumbar support, and durable urethane cushions.

Tripmeter

In addition to the hour meter, LX has added a Tripmeter. Every job or application can be measured.

AM/FM Stereo Radio

Standard equipment.

Emergency Escape Window

Allows operator to escape from the rear window in case of emergency.

Inte-LX®

Inte-LX®, the intelligent computer command control system monitors hydraulic output, pressures, and regulates engine performance for the maximum balance between speed, power and fuel efficiency needed to handle the job.

Auto Power-Up

The LX series can quickly respond to changes in operating conditions, automatically supplying a power increase, without operator interaction and regardless of the work mode. Hydraulic pressure sensors detect resistance and pressure is increased by 9% for 8 seconds. Auto Power-Up stays on 100% of the time in the "L" mode.

Anti-Theft Device

Your Link-Belt distributor can set up your Inte-LX® control system to include a password protection feature that requires the password to start and run the machine.

One-Touch and Auto Idle Control

When user-preset time has elapsed after leaving the control handles in the neutral position, auto-idling automatically drops the engine to idle speed (900 rpm). Or, you can choose to use the one-touch idling switch, located at the top of the right controller so that you are always in control.



Operating Modes

The LX series enables the operator to have a choice on how the machine is operated. Simply choose the work mode that matches the machine's output to the job application. Five operating modes are available.

A: Auto-Mode

The most revolutionary approach to maximizing power & fuel efficiency available today. Just select the Auto-Mode with the switch panel. Using actual working pressure readings, Inte-LX® instantly changes modes assuring the best combination of speed and power while you can stay focused on the work at hand.

H: Heavy Mode

For heavy excavation or whenever you need extra power.

S: Standard Mode

For standard digging and loading operations reducing fuel consumption.

L: Lift Mode

For lifting and other operations that need fingertip accuracy.



Allied Attachment Work Mode

Automatically adjusts engine speed and pump output to match additional attachments such as hammers. The engine rpm's are presettable to match the hydraulic requirements.

On-Board Diagnostics

An on-board diagnostic system allows service personnel to quickly analyze up to 148 items in four categories;

- **Machine Status:** The diagnostic system provides a detailed view of pump pressure, engine rpm, water temperature, oil temperature, fuel temperature, throttle setting and ongoing operating functions such as auto power-up and auto-mode.
- **Troubleshooting:** Service personnel can trace electrical faults such as sensor failures and harness damage.
- **History:** An on-going record of machine faults is stored in the computer including the hour meter reading at time of the fault to assist in the diagnostics procedure.
- **Systems Configuration:** Service personnel can change machine operating characteristics such as; time delay for auto-idle, language selection, and engine rpm preset for allied attachment mode.

Performance

Advanced Hydraulic System

Top-of-the-Class Cycle Times/Fuel Efficient

The LX Series hydraulic system efficiently delivers power, speed and control when and where it's needed. Fuel consumption and cycle times are more efficient in swing/dump operations over conventional models. This is accomplished through reducing system pressure loss, re-using return oil and providing double pump flow during key operations.

Regeneration System

By re-using the returning oil from the arm and the boom, ground excavating operation speed is increased.

Two Hydraulic Return Lines

Two hydraulic returns lines mean faster speed in the system, and reduces back pressure build-up.

2 Speed Boom and Arm

The 2-speed boom lifting and arm opening and closing function provides the LX series with top-of-its-class lifting speed especially in swing/excavating simultaneous operations such as truck loading.

Auto Power-Swing

This patent pending design incorporates a selector valve that helps maintain attachment and hydraulic flow to achieve excellent swing and digging forces in side wall-cut operations. In normal digging when side pressure is not needed, LX sends all the flow to the attachment always insuring the best performance for either operation.

Cushioned Swing

This built-in special cushion valve greatly reduces the shock and vibration at the end of each swing cycle.

Cushioned Attachment Control

In addition to having cushioned cylinders, selectable cushioned attachment control lets you smooth out the attachment movements. A cushion valve in the boom and arm circuits reduce shock loading and vibration during attachment operation.

Free Swing

Allows the operator to disengage the swing brake providing crane-like precision and control when handling loads.

Single Pedal Travel

Allows the operator to engage both tracks at the same time using only one pedal. This keeps the machine in line with the ditch and provides safety and ease in loading/unloading the machine for transport.

Automatic Speed Shifting

When operating in difficult travel conditions, the travel motor automatically downshifts from high to low speed for increased tractive effort and then automatically returns to high speed when travel conditions permit.

Fuel Tank Capacity

The LX Series fuel tank provides the capacity to reduce refueling frequency, allowing for an extended work day.



Dependable Isuzu Power



First In Class

The 290 LX is the first excavator in its class to utilize an electronic engine control function. By optimizing the level of fuel injection to match the load, this responsive new system assures more efficient use of fuel, plus by keeping the engine closer to the target engine speed, less lugging takes place so cycle times are faster, exhaust noise, vibration, and smoke are reduced making the environment in the cab and around the machine cleaner and quieter.

Electronic Engine Control (EEC)

Inte-LX® maintains engine rpm's when load demands change. Engines equipped with mechanical governors spike rpm's up-and-down when operating loads increase and decrease. This phenomena causes engines to consume extra fuel and be louder.

Tier II Compliant

LX engines have already met year 2003 EPA standards requirements.

Idle Start

At start-up, the engine defaults to idle regardless of throttle position. This prevents over revving a cold engine, helping to extend its service life.

Low Idle Up

When low temperatures or other conditions reduce engine rpm to a point that alternator output won't keep the battery charged, Inte-LX® automatically increases the idle speed from 900 to 1100 rpm keeping the batteries fully charged.

Auto Engine Warm-Up

If the engine temperature is low following start-up, the auto warm-up system will operate automatically and continue with engine speed increasing gradually until normal engine operating temperatures are reached.

Air Filtration

LX Series engines are equipped with a dual element air filter with an evacuator cup, a restriction indicator and ground level serviceability for ease of maintenance.

Bell-Mouth Type Fan Housing

Since the bell-mouth shaped fan housing is secured to the engine, there is less clearance

between the fan and the fan housing, assuring a smoother air flow with reduced noise and increased cooling capability.

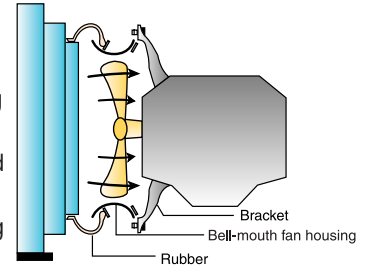

Larger Muffler

The LX series features a larger muffler which absorbs more sound and makes this the quietest Link-Belt yet.

Emergency Engine Shutdown

In emergency situations, the engine can be shut down with the push of a switch located on the control panel in the cab. This switch must be re-engaged prior to restarting the engine.

Engine Product Support

Isuzu North America offers 24-hour access to their full line of engine parts through 2 regional distribution centers, 27 Master Distributors and 690 Authorized Service Dealers.

Advantages of EEC

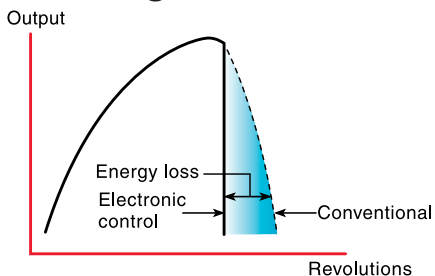

Maintaining engine revolution at a fixed rate regardless of the load prevents the energy loss that occurs when shifting cycle times to accommodate higher or lower loads.

Low Fuel Consumption

The electronic governor responds to changes in operating loads quicker than a mechanical governor. As a result, EEC regulates the amount of fuel injection accurately and quickly.

Lower, Cleaner Emissions

Low fuel consumption results in high ignition efficiency (cleaner emission) and low emissions.

Low Sound Levels

At high idle, EEC can control engine speed at rated horsepower. This means the engine doesn't overrun, resulting in lower sound levels.

Low Vibration

EEC causes engine rpm to be stable, resulting in low vibration.

Upper and Attachments

Powerful Breakout Forces

Deep and wide box sections of high yield steel and deep groove welding hold up to high breakout forces, strong lifting capacities and the stresses of **allied attachments** such as hammers, thumbs, compactors, shears, grapples and crushers.

Strength and Durability

LX heavy duty booms and arms have internal baffles which provide better strength and durability to withstand torsional loads.

Improved Pin and Bushing Life

Chrome plated boom foot and boom to arm pins mounted in grease impregnated



brass bushings make a durable and long lasting connection at the two highest stress points on the attachment. This also makes it possible to extend the lubrication interval on this type of pin to once every 6 months or 1,000 hours of operation, whichever comes first.

- A. The surface of the bushing is stratified with a solid lubricant in hard brass to protect the parts from abrasion.
- B. The pin's surface is plate-processed to increase hardness and protect from abrasion
- C. The original dust seal is double-structured to keep out dust and dirt and protect from subsequent abrasion.

Three Arm Choices and a wide variety of buckets provide the reach and breakout forces for optimum productivity.

Undercarriage

LC Undercarriage

Long undercarriages incorporate heavy duty excavator style components and improve both stability and ground bearing pressure. The modified X style carbody is integrally welded for maximum strength and durability. High torque compact final drives keep you going up steep grades and through deep mud.

Bearing Tub

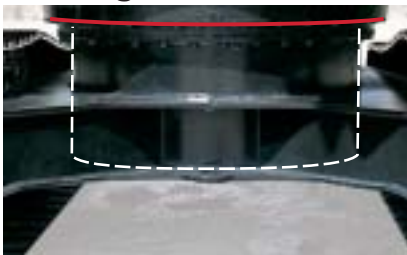

Built into the "X" style carbody is the turntable bearing "tub" which extends down through the top plate and is welded to the bottom of the carbody as well as the top for increased strength and durability.



Two-Speed Travel Motor

Offers smooth shifting and the needed pull when going up grades and making turns.

Strut Type Chain Links

There are no weak links in our chain. Struts reduce twisting and hold up to severe point loading when all of the machine weight is transferred through one roller.

Track Rollers

Filled with synthetic oil to reduce heat build up and for long term reliability.

Track Adjustment

Adjustments are made easy with standard grease cylinder track adjusters and shock absorbing springs.

Side Frames

Incorporate a peaked saddle shape and large cut-outs on top for reduced dirt build-up.

Reliability/Serviceability

Nephron® Filtration Extends the Service Life of the Hydraulic System

The Nephron® Filtration System eliminates contaminants of 1 micron or more in size. This significantly reduces hydraulic system breakdown and maintenance costs under normal usage. Less wear and tear on the hydraulic components means more years of reliable performance.

Nephron® Filter Advantages

1. Problems associated with hydraulic system contamination are substantially reduced. Machine down time and costs for repairing are saved as a consequence.
2. The interval of hydraulic oil replacement is extended to every 5000 hours.
3. The wear of hydraulic components is reduced, which lengthens the service life of the machine.

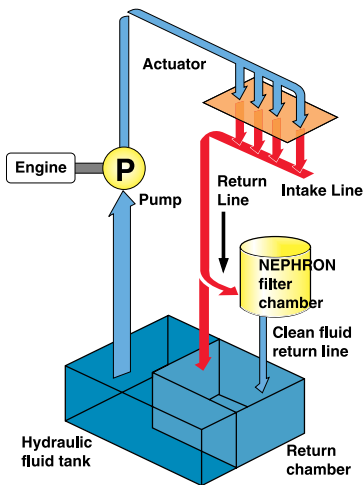

Inte-LX® On-Board Diagnostics

Inte-LX® monitors, stores, and displays information about the electrical and hydraulic systems such as; the current machine conditions, diagnostic warnings, history, and machine default settings. Information stored in Inte-LX® can also be downloaded to your personal computer using standard connectors.

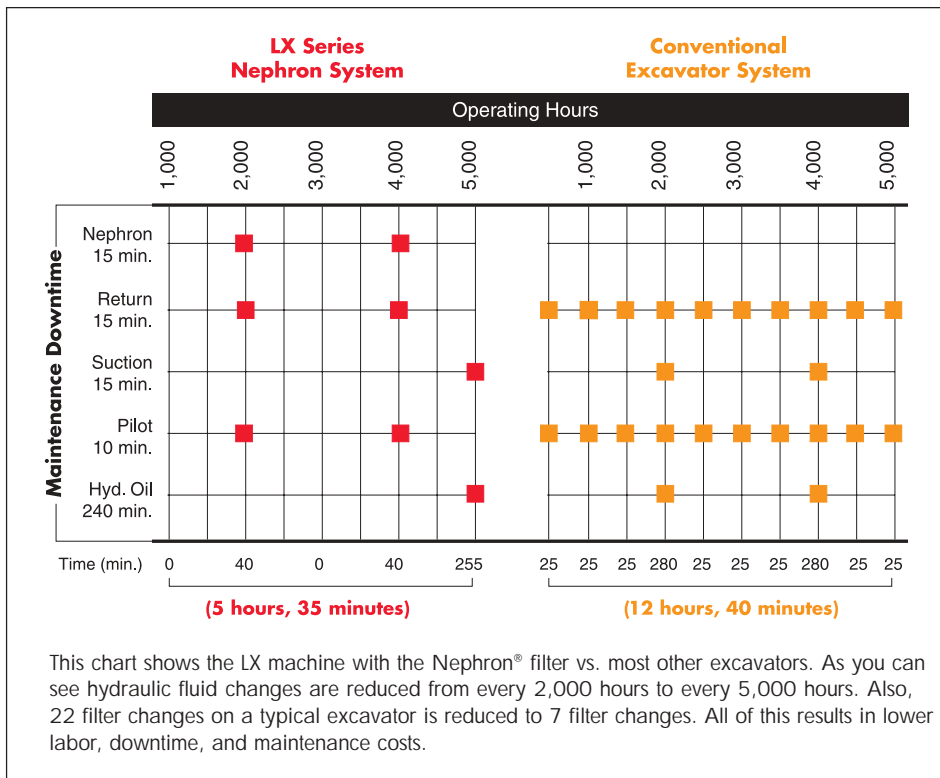

Large wide opening access doors

These doors make it easy to get to all routine maintenance locations.

Hydraulic Fittings

"O" ring seals are used as hydraulic connectors to assure tighter seals.

Air Conditioner Air Intake Filter

This filter lets in fresh clean air and is mounted on the outside of the cab, enabling easy cleaning and replacement.

Sealed Automotive Style Wiring Harness

These harnesses are sealed to eliminate dirt and moisture that can cause a circuit to short out. Wiring is also color and number coded to make trouble shooting faster and easier.

Exceptional Customer/Product Support

Your investment in the Link-Belt LX Series Excavator is always protected. LBX Distribution is located from coast to coast; you're never far from quality service professionals. "Level Two" support takes the form of experienced factory service advisors, on-call at a moment's notice. And to expedite parts, LBX utilizes the proven parts system LINK-NET...an on-line, around the clock parts distribution solution. You can be assured that we have the parts when you need them.

Specifications

Engine

Isuzu CC-6BG1TC Electric engine control, water cooled, 4-cycle diesel, 6 cylinder, turbocharged with air cooled intercooler, 396 CID (6 494 cc), 4.13" (105 mm) bore x 4.92" (125 mm) stroke. EPA Tier II compliant.

SAE net horsepower .. 177 HP (132 kW) @ 2,200 rpm
 Maximum torque . 443 ft.-lbs. (600 N-m) @ 1,800 rpm
 Starter Electric, 24V
 Alternator 50 amp
 Battery Cold Cranking 780 amps
 Air cleaner Double element
 Governor Electronic

Fuel Usage*

Heavy 6.1 gph (23.09 l/hr)
 Average 5.0 gph (18.93 l/hr)
 Light 4.0 gph (15.14 l/hr)

*Fuel economy varies widely depending upon application.

The "heavy" category represents nearly continuous operation in tough digging applications. The "light" category represents applications that utilize the machine about 50% of the time in easier digging.

Hydraulic System

Two variable displacement axial piston pumps and one gear pump for pilot controls, with Link-Belt Inte-LX® Control System. Link-Belt Inte-LX® Control includes: electric engine control, five selectable working modes, automatic power-up, auto/one touch idling, automatic speed shifting, free swing, cushioned attachment, swing anti-braking system, and two safety lockout switches including gate lock.

Hydraulic Pumps

Two variable volume piston pumps provide power for attachment, swing and travel.

Maximum flow 2 x 58.4 gpm (2 x 221 l/min)
 Pilot pump max. flow 5.8 gpm (22 l/min)

Relief Valve Settings

Boom/arm/bucket 4,970 psi (350 kg/cm²)
 in Power-Up Mode 5,410 psi (380 kg/cm²)
 Swing circuit 4,260 psi (300 kg/cm²)
 Travel 4,970 psi (350 kg/cm²)

Hydraulic Cylinders – number of cylinders – bore x rod x stroke.

Boom 2 – 5.3" x 3.7" x 53.9"
 (135 mm x 95 mm x 1 369 mm)
 Arm 1 – 5.9" x 4.1" x 56.6"
 (150 mm x 105 mm x 1 408 mm)
 Excavator Bucket 1 – 5.1" x 3.5" x 42.2"
 (130 mm x 90 mm x 1 073 mm)

Oil Filtration

Nephron® filter 1 micron
 Return, pilot 10 micron
 Suction filter 105 micron

Control Valve One 4-spool valve and one 5-spool valve with auxiliary spool.

Cab and Controls

Cab mounted on 6 fluid filled mountings. Features include a safety glass front window and LEXAN® MARGARD™ rear and side windows, reclining/sliding suspension seat with headrest, armrests, lumbar support, heater, air conditioner, AM/FM stereo, cigarette lighter, pop-up skylight window, and intermittent wiper with washer. Front window slides upward for storage and the lower front window is removable. Control levers are located in 3-position tilting control consoles. Reliable soft-touch switches. Easy-to-read illuminated LCD service monitor keeps operator in touch with critical machine functions.

Heater output 20,240 BTU/hr (5 100 kcal/hr)
 A/C output 18,250 BTU/hr (4 600 kcal/hr)
 Noise level (inside cab) 68 dB(A)
 Noise level (exterior) 103 dB(A)

Swing

Planetary reduction powered by axial piston motor. Internal ring gear with grease cavity for swing pinion. Swing bearing is single-row shear type ball bearing. Swing cushion valve and dual stage relief valves for smooth swing deceleration and stops. Mechanical disc swing brake. Auto power swing.

Swing speed 0 – 10.4 rpm
 Tail swing 10' 5" (3.18 m)
 Swing torque 55,130 ft.-lbs. (7 624 kg.-m.)

Undercarriage

X-style carbody is integrally welded for strength and durability. Grease cylinder track adjusters with shock absorbing springs. LC undercarriage with sealed track, lubricated rollers and idlers. Three-bar grouser track shoes.

Carrier rollers 2 per side
 Track rollers 8 per side
 Track link pitch 8.5" (216 mm)
 Shoes 47 per side
 Shoe width 31.5" (800 mm)
 Ground pressure 6.09 psi (.43 kg/cm²)

Travel System

Two-speed independent hydrostatic travel with compact axial piston motors for increased performance. Hydraulic motor powered output shaft coupled to a planetary reduction unit and track sprocket. All hydraulic components mounted within the width of side frame.

Automatic Downshift: When operating in difficult travel conditions, the travel motor automatically downshifts from high to low speed for increased tractive effort and then automatically returns to high speed when travel conditions permit.

Max. travel speed 1.9/3.2 mph (3.0/5.1 km/h)
 Traction force 50,220 lbs. (22 779 kg)
 Gradeability 70%

Spring applied, hydraulically released disc parking brake built into each motor. Each travel motor equipped with counterbalance valve to prevent overspeeding down an incline and 3-stage reliefs for smooth starts and stops.

Lubricant and Coolant Capacity

Hydraulic tank 32 gal. (120 liters)
 Hydraulic system 63 gal. (240 liters)
 Final drive (per side) 1.2 gal. (4.7 liters)
 Swing drive 1.6 gal. (6.0 liters)
 Engine 6.3 gal. (24 liters)
 Fuel tank 90 gal. (340 liters)
 Cooling system 7.7 gal. (29 liters)

Attachment

Boom 20' 2" (6.15 m)

Available Arms	Digging Force*
• 10' 6" (3.20 m)	25,850 lbs. (11 725 kg)
in Auto Power-Up Mode ...	28,100 lbs. (12 746 kg)
• 8' 9" (2.67 m)	29,230 lbs. (13 258 kg)
in Auto Power-Up Mode ...	31,920 lbs. (14 479 kg)
• 12' 0" (3.66 m)	23,600 lbs. (10 705 kg)
in Auto Power-Up Mode	25,630 lbs. (11 625 kg)
Bucket Digging Force	35,970 lbs. (16 315 kg)
in Auto Power-Up Mode	38,890 lbs. (17 640 kg)

*Digging force ratings are based on ISO 6015, "Earthmoving Machinery – Hydraulic Excavators – Tool Forces".

Operating Weight

Standard Excavator - Working weight with 31.5" (800 mm) shoes, 20' 2" (6.15 m) boom, 10' 6" (3.20 m) arm 1,780 lb. (806 kg) bucket, 11, 930 lb. (5 410 kg) counterweight
 64,400 lbs. (29 200 kg)

Specifications (continued)

Working Ranges

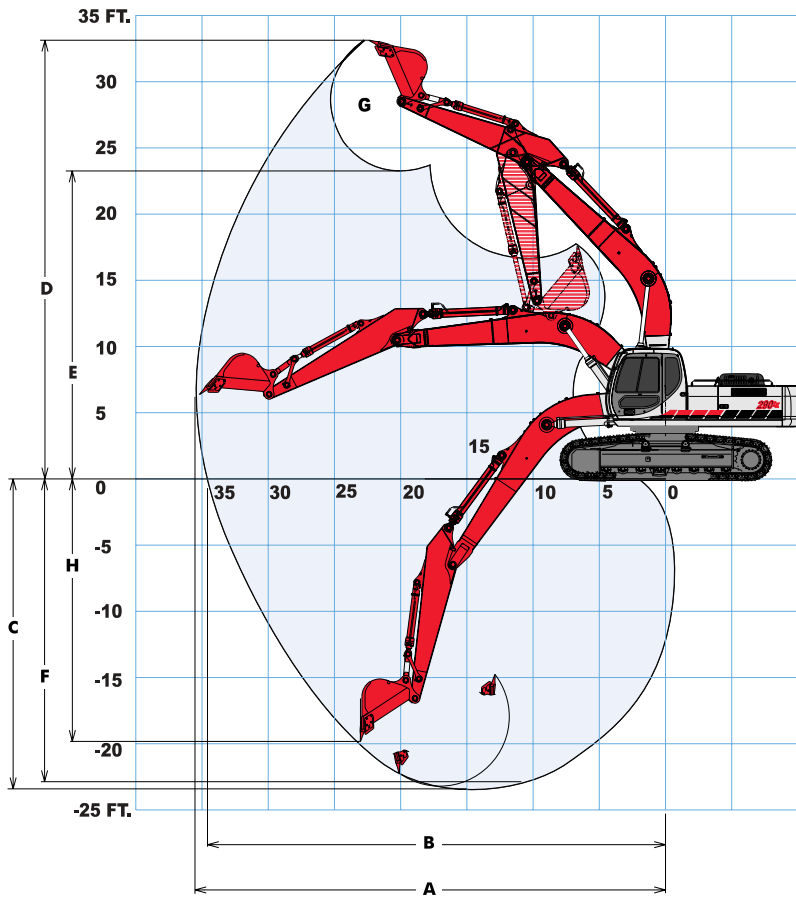

Machine equipped with 20' 2" (6.15 m) boom.	10' 6" Arm (3.20 m)	8' 9" Arm (2.67 m)	12' 0" Arm (3.66 m)
A Max. digging radius	35' 2" (10.72 m)	33' 9" (10.29 m)	36' 8" (11.18 m)
B Max. digging radius @ ground level	34' 7" (10.54 m)	33' 2" (10.10 m)	36' 1" (11.00 m)
C Max. digging depth	23' 5" (7.13 m)	21' 8" (6.6 m)	24' 11" (7.59 m)
D Max. digging height	33' 2" (10.10 m)	32' 10" (10.01 m)	34' 1" (10.39 m)
E Max. dumping height	23' 3" (7.09 m)	22' 10" (6.97 m)	24' 2" (7.36 m)
F Digging depth - 8' (2.44 m) level bottom	22' 10" (6.97 m)	21' 1" (6.42 m)	24' 5" (7.45 m)
G Bucket wrist angle	176°	176°	176°
H Max. vertical wall depth	19' 10" (6.04 m)	18' 7" (5.66 m)	21' 10" (6.65 m)

Dimensions

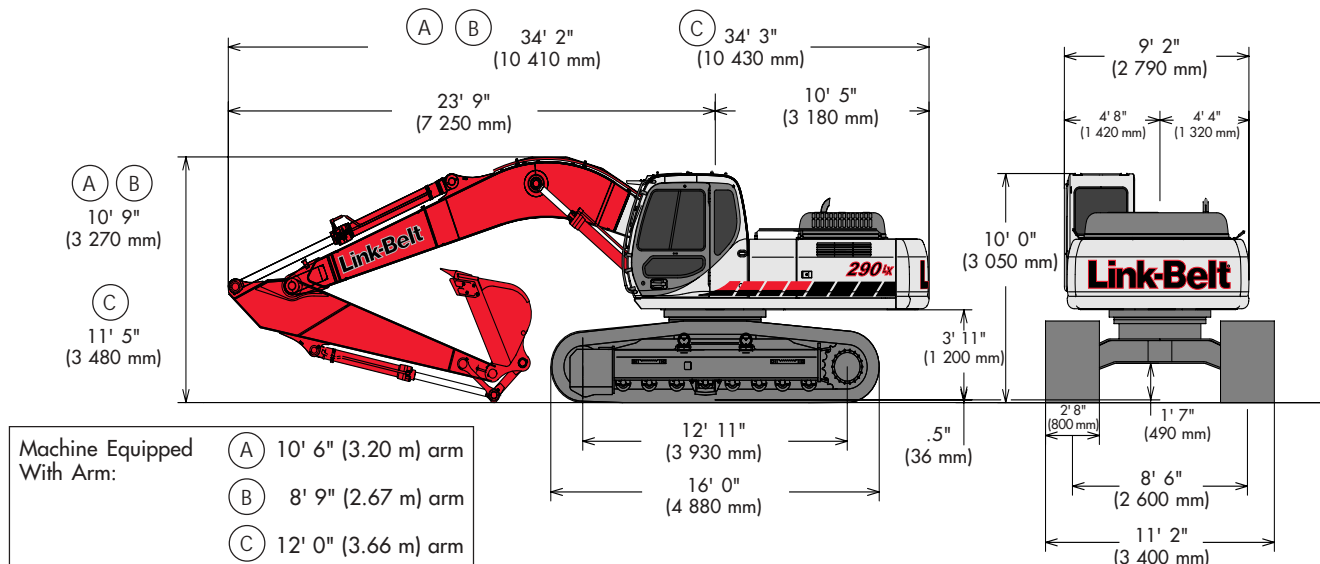

Machine Equipped With Arm:	(A) 10' 6" (3.20 m) arm
	(B) 8' 9" (2.67 m) arm
	(C) 12' 0" (3.66 m) arm

Lifting Capacities

10' 6" (3.20 m) Arm

with 20' 2" (6.15 m) Boom and 1,780 lb. (806 kg) Bucket. Auto Power-Up Mode Applied

Bucket Hook Height		Radius of Load									
		10' 0" (3.05 m)		15' 0" (4.57 m)		20' 0" (6.10 m)		25' 0" (7.62 m)		Cap. at Max. Reach	
		End	Side	End	Side	End	Side	End	Side	End	Side
+25' 0" (7.62 m)	lbs. kg									8,370* 3,790*	8,370* 3,790*
+20' 0" (6.10 m)	lbs. kg							10,820* 4,910*	10,820* 4,910*	8,190* 3,710*	8,190* 3,710*
+15' 0" (4.57 m)	lbs. kg					16,210* 7,350*	16,070 7,290	14,510* 6,580*	11,080 5,030	8,410* 3,810*	8,410* 3,810*
+10' 0" (3.05 m)	lbs. kg	39,640* 17,980*	39,640* 17,980*	24,680* 11,190*	23,680 10,740	18,870* 8,560*	15,110 6,850	15,910* 7,220*	10,590 4,800	8,990* 4,070*	7,940 3,600
+5' 0" (1.52 m)	lbs. kg	14,470* 6,560*	14,470* 6,560*	29,700* 13,470*	21,790 9,880	21,460* 9,730*	14,180 6,430	15,900 7,210	10,100 4,580	10,000* 4,540*	7,610 3,450
Ground Line	lbs. kg	18,200* 8,250*	18,200* 8,250*	32,240* 14,620*	20,710 9,390	21,910 9,940	13,500 6,120	15,470 7,010	9,700 4,400	11,720* 5,310*	7,680 3,480
-5' 0" (1.52 m)	lbs. kg	25,820* 11,710*	25,820* 11,710*	32,240* 14,620*	20,310 9,210	21,520 9,760	13,150 5,960	15,240 6,910	9,490 4,300	13,170 5,970	8,240 3,730
-10' 0" (3.05 m)	lbs. kg	35,880* 16,270*	35,880* 16,270*	30,000* 13,600*	20,370 9,240	21,490 9,740	13,130 5,950			15,390 6,980	9,600 4,350
-15' 0" (4.57 m)	lbs. kg	34,310* 15,560*	34,310* 15,560*	25,020* 11,340*	20,840 9,450	18,370* 8,330*	13,470 6,110			17,580* 7,970*	12,880 5,840

8' 9" (2.67 m) Arm

with 20' 2" (6.15 m) Boom and 1,780 lb. (806 kg) Bucket. Auto Power-Up Mode Applied

Bucket Hook Height		Radius of Load									
		10' 0" (3.05 m)		15' 0" (4.57 m)		20' 0" (6.10 m)		25' 0" (7.62 m)		Cap. at Max. Reach	
		End	Side	End	Side	End	Side	End	Side	End	Side
+25' 0" (7.62 m)	lbs. kg									10,620* 4,820*	10,620* 4,820*
+20' 0" (6.10 m)	lbs. kg					15,660* 7,100*	15,660* 7,100*			10,390* 4,710*	10,390* 4,710*
+15' 0" (4.57 m)	lbs. kg					17,500* 7,940*	15,780 7,160	15,550* 7,050*	10,920 4,950	10,700* 4,850*	9,510 4,310
+10' 0" (3.05 m)	lbs. kg			26,730* 12,120*	23,060 10,460	20,000* 9,070*	14,850 6,740	16,310 7,390	10,470 4,750	11,500* 5,210*	8,590 3,890
+5' 0" (1.52 m)	lbs. kg			31,070* 14,090*	21,380 9,690	22,300* 10,110*	14,000 6,350	15,820 7,170	10,030 4,550	12,920* 5,860*	8,220 3,730
Ground Line	lbs. kg	16,180* 7,340*	16,180* 7,340*	32,610* 14,790*	20,570 9,330	21,830 9,900	13,430 6,090	15,460 7,010	9,700 4,400	13,260 6,010	8,340 3,780
-5' 0" (1.52 m)	lbs. kg	27,340* 12,400*	27,340* 12,400*	31,710* 14,380*	20,380 9,240	21,560 9,780	13,200 5,980	15,320 6,950	9,570 4,340	14,470 6,560	9,060 4,110
-10' 0" (3.05 m)	lbs. kg	39,030* 17,700*	39,030* 17,700*	28,600* 12,970*	20,590 9,340	21,440* 9,720*	13,290 6,030			17,360 7,870	10,830 4,910
-15' 0" (4.57 m)	lbs. kg	29,620* 13,430*	29,620* 13,430*	22,360* 10,140*	21,220 9,620					17,890* 8,110*	15,500 7,030

12' 0" (3.66 m) Arm

with 20' 2" (6.15 m) Boom and 1,780 lb. (806 kg) Bucket. Auto Power-Up Mode Applied

Bucket Hook Height		Radius of Load											
		10' 0" (3.05 m)		15' 0" (4.57 m)		20' 0" (6.10 m)		25' 0" (7.62 m)		30' 0" (9.14 m)		Cap. at Max. Reach	
		End	Side	End	Side	End	Side	End	Side	End	Side	End	Side
+25' 0" (7.62 m)	lbs. kg							7,480* 3,390*	7,480* 3,390*			7,060* 3,200*	7,060* 3,200*
+20' 0" (6.10 m)	lbs. kg							10,730* 4,870*	10,730* 4,870*			6,870* 3,110*	6,870* 3,110*
+15' 0" (4.57 m)	lbs. kg							13,220* 6,000*	11,180 5,070	7,550* 3,420*	7,550* 3,420*	6,990* 3,170*	6,990* 3,170*
+10' 0" (3.05 m)	lbs. kg	35,180* 15,960*	35,180* 15,960*	22,710* 10,300*	22,710* 10,300*	17,720* 8,040*	15,280 6,930	15,110* 6,850*	10,650 4,830	10,170* 4,610*	7,790 3,530	7,380* 3,340*	7,220 3,270
+5' 0" (1.52 m)	lbs. kg	18,710* 8,490*	18,710* 8,490*	28,200* 12,790*	22,100 10,020	20,540* 9,320*	14,280 6,470	15,920 7,220	10,110 4,580	11,880 5,390	7,500 3,400	8,090* 3,670*	6,920 3,140
Ground Line	lbs. kg	18,310* 8,300*	18,310* 8,300*	31,520* 14,300*	20,780 9,420	21,930 9,950	13,500 6,120	15,430 7,000	9,660 4,380	11,620 5,270	7,260 3,290	9,270* 4,200*	6,960 3,150
-5' 0" (1.52 m)	lbs. kg	23,890* 10,830*	23,890* 10,830*	32,290* 14,650*	20,190 9,160	21,430 9,720	13,060 5,920	15,120 6,860	9,380 4,250			11,280* 5,110*	7,400 3,350
-10' 0" (3.05 m)	lbs. kg	32,210* 14,610*	32,210* 14,610*	30,790* 13,960*	20,120 9,120	21,290 9,650	12,940 5,870	15,070 6,830	9,330 4,230			13,600 6,170	8,450 3,830
-15' 0" (4.57 m)	lbs. kg	37,690* 17,090*	37,690* 17,090*	26,750* 12,130*	20,460 9,280	19,780* 8,970*	13,150 5,960					16,390* 7,430*	10,810 4,900
-20' 0" (6.10 m)	lbs. kg			18,490* 8,380*	18,490* 8,380*							16,250* 7,370*	16,250* 7,370*

Notes: Excavator lifting capacities

- Lifting capacities shown should not be exceeded. Weight of all lifting accessories must be deducted from the above lifting capacities.
- Lifting capacities are based on machine standing on firm, uniform supporting surface. User must make allowances for job conditions such as soft or uneven ground.
- Lifting capacities shown do not exceed 75% of minimum tipping loads or 87% of hydraulic capacities. Capacities marked with an asterisk (*) are limited by hydraulic capacities.
- Least stable position is over the side.
- Operator should be fully acquainted with the Operator's Manual & Operating Safety Booklet, furnished by LBX before operating the machine.
- Capacities apply only to the machine as originally manufactured and normally equipped by LBX Company, LLC.
- Lift capacity ratings are based on SAE J/ISO 10567, "Earthmoving Machinery - Hydraulic Excavators - Lift Capacity".



Specifications (continued)

Bucket Sizes

Bucket Type	Capacity	Width Outside Lip	Weight	# Teeth	Arm	Arm	Arm
					8' 9" (2.67 m)	10' 6" (3.20 m)	12' 0" (3.66 m)
ESCO STDP	.79 cu. yd. (.60 m ³)	24" (610 mm)	1,571 lb. (713 kg)	4	H	H	H
	1.05 cu. yd. (.80 m ³)	30" (762 mm)	1,702 lb. (772 kg)	4	H	H	H
	1.32 cu. yd. (1.01 m ³)	36" (914 mm)	1,909 lb. (866 kg)	5	H	H	H
	1.60 cu. yd. (1.22 m ³)	42" (1 067 mm)	2,075 lb. (941 kg)	5	H	H	M
	1.87 cu. yd. (1.43 m ³)	48" (1 219 mm)	2,206 lb. (1 001 kg)	5	M	M	L
	2.15 cu. yd. (1.64 m ³)	54" (1 372 mm)	2,413 lb. (1 095 kg)	6	M	L	L
ESCO HDP	2.43 cu. yd. (1.86 m ³)	60" (1 524 mm)	2,544 lb. (1 154 kg)	6	L	L	N/A
	.79 cu. yd. (.60 m ³)	24" (610 mm)	2,003 lb. (909 kg)	3	H	H	H
	1.05 cu. yd. (.80 m ³)	30" (762 mm)	2,267 lb. (1 028 kg)	4	H	H	H
	1.32 cu. yd. (1.01 m ³)	36" (914 mm)	2,472 lb. (1 121 kg)	4	H	H	H
	1.59 cu. yd. (1.22 m ³)	42" (1 067 mm)	2,737 lb. (1 242 kg)	5	H	M	M
	1.87 cu. yd. (1.43 m ³)	48" (1 219 mm)	2,941 lb. (1 334 kg)	5	M	L	L
ESCO XDP	2.15 cu. yd. (1.64 m ³)	54" (1 372 mm)	3,206 lb. (1 454 kg)	6	L	L	N/A
	.93 cu. yd. (.71 m ³)	30" (762 mm)	2,635 lb. (1 195 kg)	4	H	H	H
	1.17 cu. yd. (.89 m ³)	36" (914 mm)	2,874 lb. (1 304 kg)	4	H	H	H
	1.42 cu. yd. (1.09 m ³)	42" (1 067 mm)	3,194 lb. (1 449 kg)	5	H	M	M
ESCO HDC	1.67 cu. yd. (1.28 m ³)	48" (1 219 mm)	3,433 lb. (1 557 kg)	5	M	M	L
	.96 cu. yd. (.73 m ³)	30" (762 mm)	2,161 lb. (980 kg)	4	H	H	H
	1.08 cu. yd. (.83 m ³)	33" (838 mm)	2,247 lb. (1 019 kg)	4	H	H	H
	1.34 cu. yd. (1.02 m ³)	39" (991 mm)	2,511 lb. (1 139 kg)	5	H	H	H
ESCO DITCH	1.59 cu. yd. (1.22 m ³)	45" (1 143 mm)	2,709 lb. (1 229 kg)	5	H	M	M
	2.02 cu. yd. (1.54 m ³)	55" (1 397 mm)	3,198 lb. (1 451 kg)	6	L	L	L
ESCO DITCH	1.30 cu. yd. (.99 m ³)	60" (1 524 mm)	1,767 lb. (802 kg)	0	H	H	H
	1.45 cu. yd. (1.11 m ³)	66" (1 676 mm)	1,928 lb. (875 kg)	0	H	H	M

Approval Code For Arm/Bucket Combinations

H Heavy material
(up to 3,370 lbs./cu. yd.)
M Medium material
(up to 2,700 lbs./cu. yd.)
L Light material
(up to 2,020 lbs./cu. yd.)
N/A ... Not applicable

Standard Equipment

- Inte-LX® Computer System
- Self-diagnostic system
- Five selectable working modes
- One-touch decelerator
- Auto idling system
- Auto idle start
- Low idle up
- Auto engine warm up
- Auto power-up mode
- Integral cylinder cushioning
- Cushioned attachment control
- Boom and arm holding valves
- Free swing control
- Auto power swing
- Single Pedal Travel
- Travel Alarm
- Nephron® filtration system
- Low noise/low vibration cab floating on 6 fluid filled mounts
- Sliding/reclining, suspension cloth upholstered seat with adjustable arm rests and lumbar support, retracting seat belt
- 3-position tilting consoles
- 4th position on left console for entering and exiting the cab also serves as control lock-out

- Illuminated LCD service monitor
- Climate control heater and air conditioner
- Hand grab rails both sides
- Rear view mirror, coat hook, storage compartment
- Horn, interior lighting, AM/FM STEREO radio, digital clock, floor mat, cigarette lighter
- Safety glass front windows with automatic lock and intermittent rise-up windshield wiper and washer, large LEXAN® rear/side windows
- Gate lock and gate lock lever (control lock-out device)
- Vandalism locks/guarding
- Common key for cab & house doors, engine hood, tool box, and fuel cap
- Upper and lower undercovers
- LC undercarriage
- Chrome plated boom foot pin with oil impregnated bushing
- Chrome plated boom to arm connection pin with oil impregnated bushing
- 11,930 lbs. (5 410 kg) counterweight

Options

- Arms
 - 8' 9" (2.67 m)
 - 10' 6" (3.20m)
 - 12' 0" (3.66 m)
- Track
 - 31.5" (800 mm) 3-Bar Grouser
 - 27.5" (700 mm) 3-Bar Grouser
- Auxiliary Hydraulics
 - Single Acting
 - Multi-Function
 - Thumb
- Hose Burst Check Valves
- Couplers (field install)
 - Hendrix Hydraulic Coupler
 - Esco Multi-Pin Grabber
- Thumbs (field install)
 - Esco Universal rigid
 - Esco Hydraulic non-link
 - Esco Hydraulic non-link (for coupler)
 - Esco Hydraulic link